

Lecture 19
EE 2303/001-Electronics I
April 1, 2009

Professor Ronald L. Carter
ronc@uta.edu
<http://www.uta.edu/ronc/>

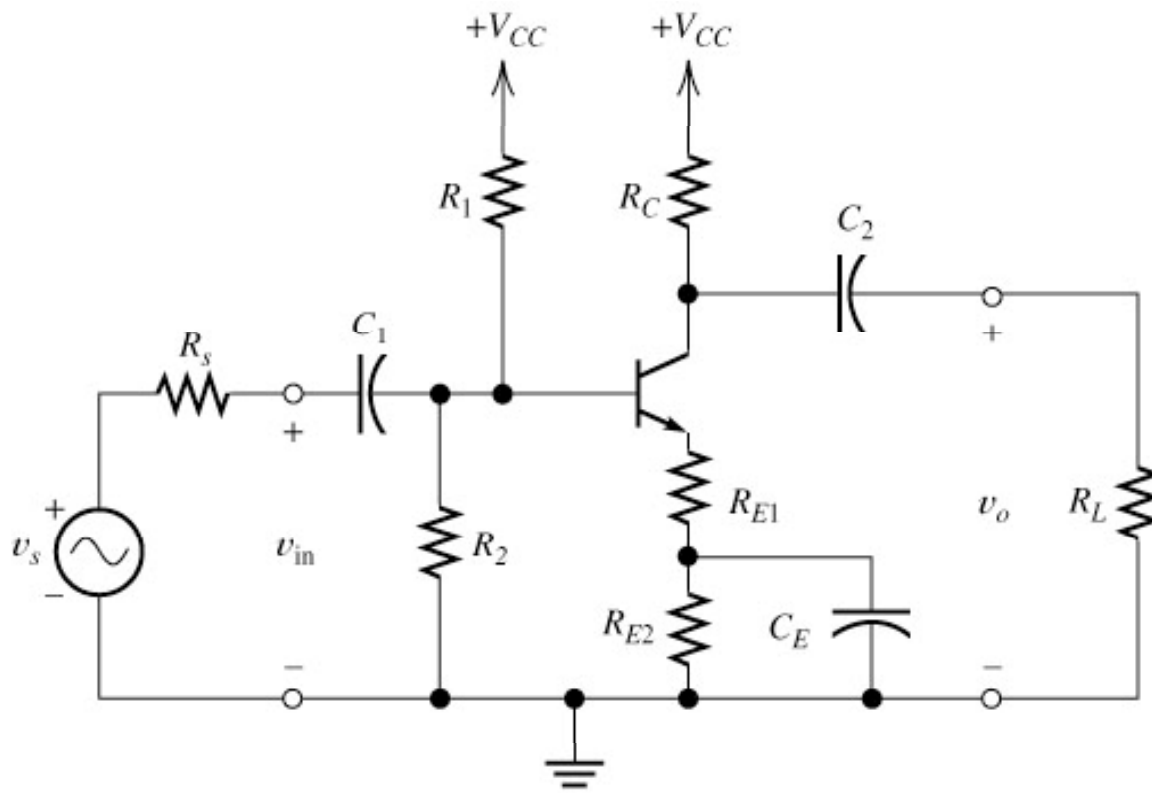

(a) Actual circuit

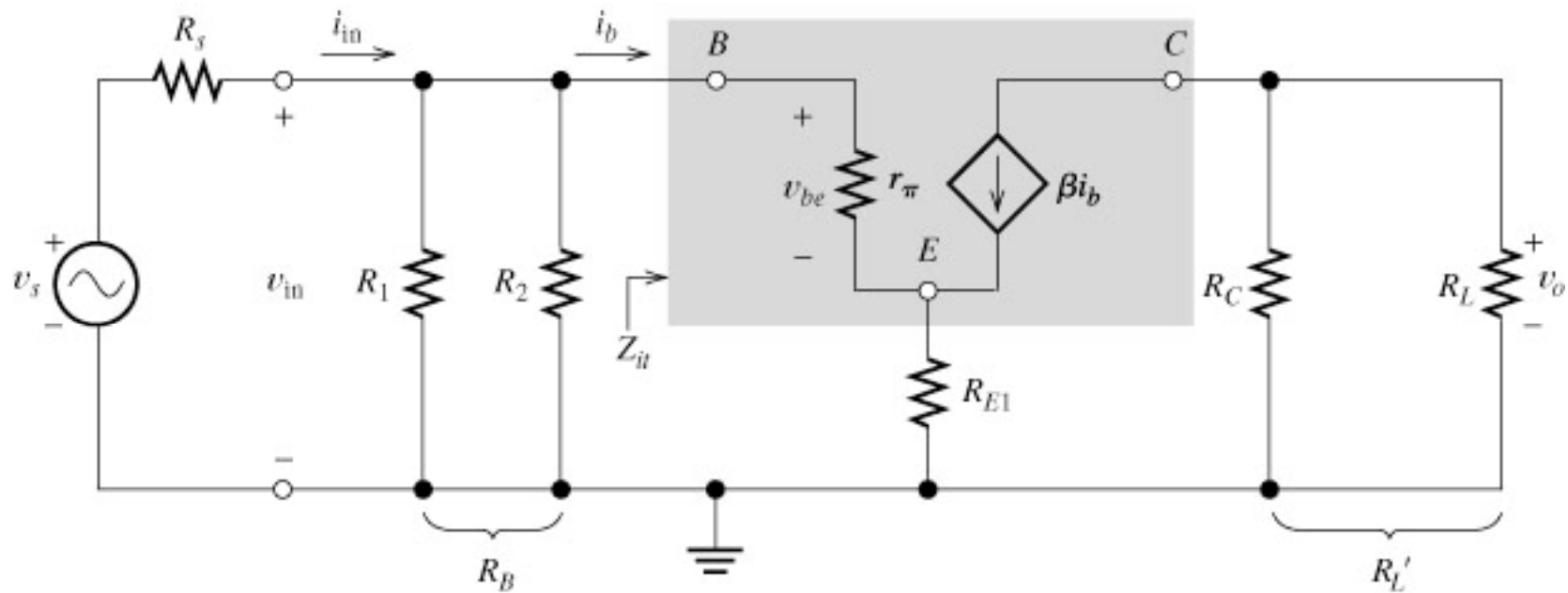

(b) Small-signal midband equivalent circuit

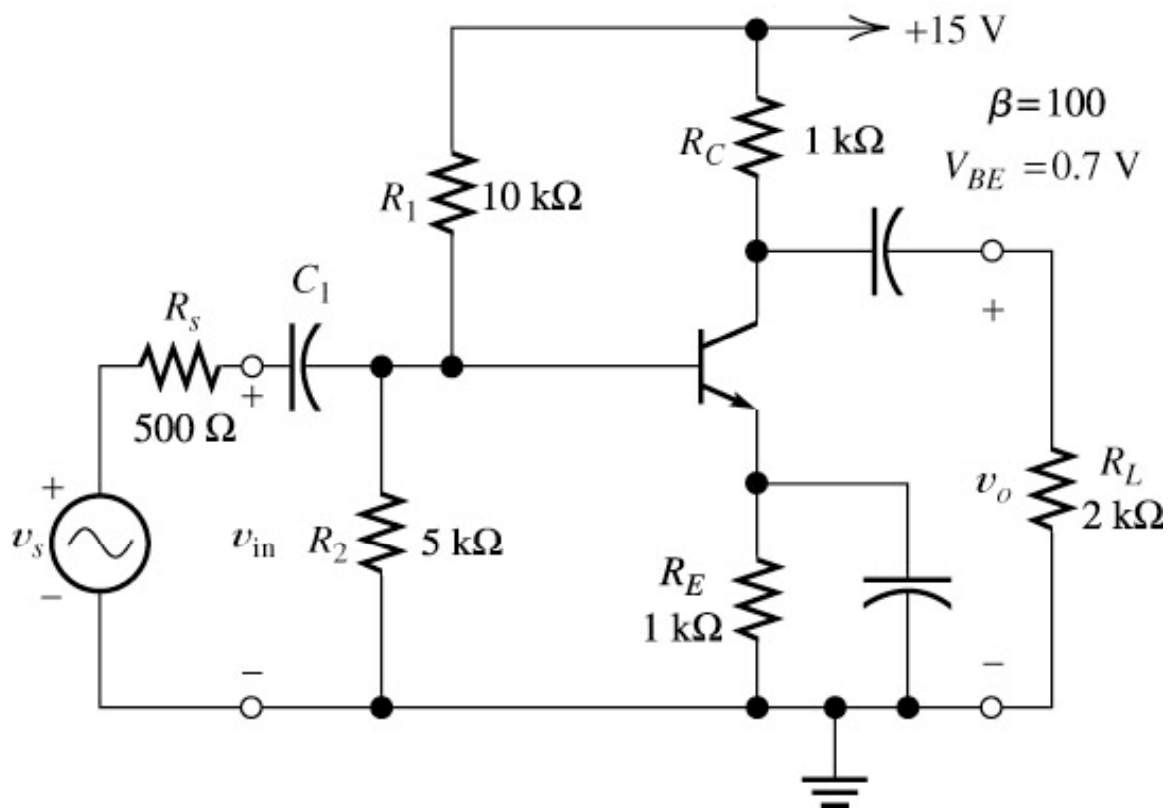

L19 - 01Apr09 **Figure 4.35** Common-emitter amplifier of Example 4.9.

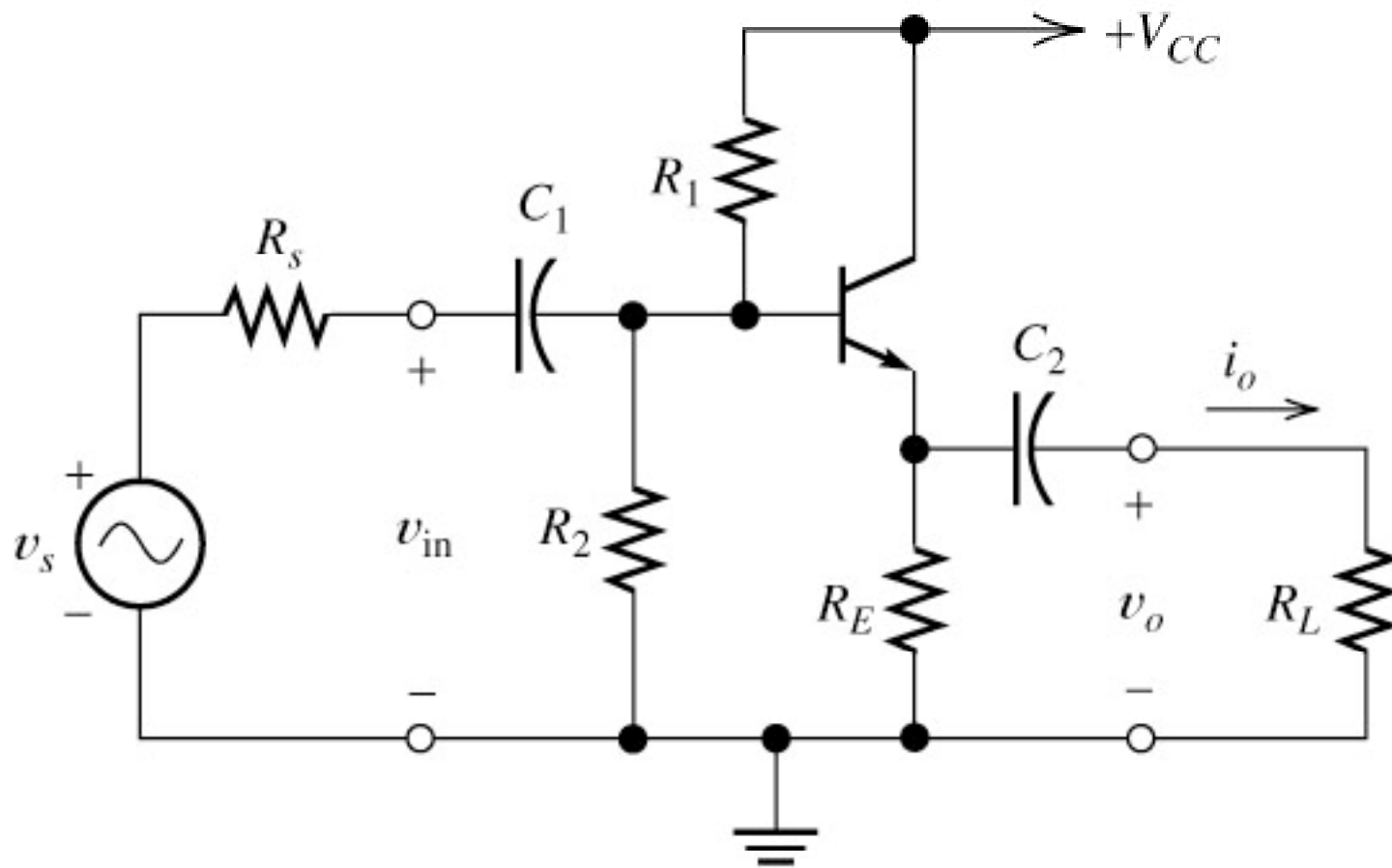

(a) Actual circuit

Figure 4.36a Emitter follower.

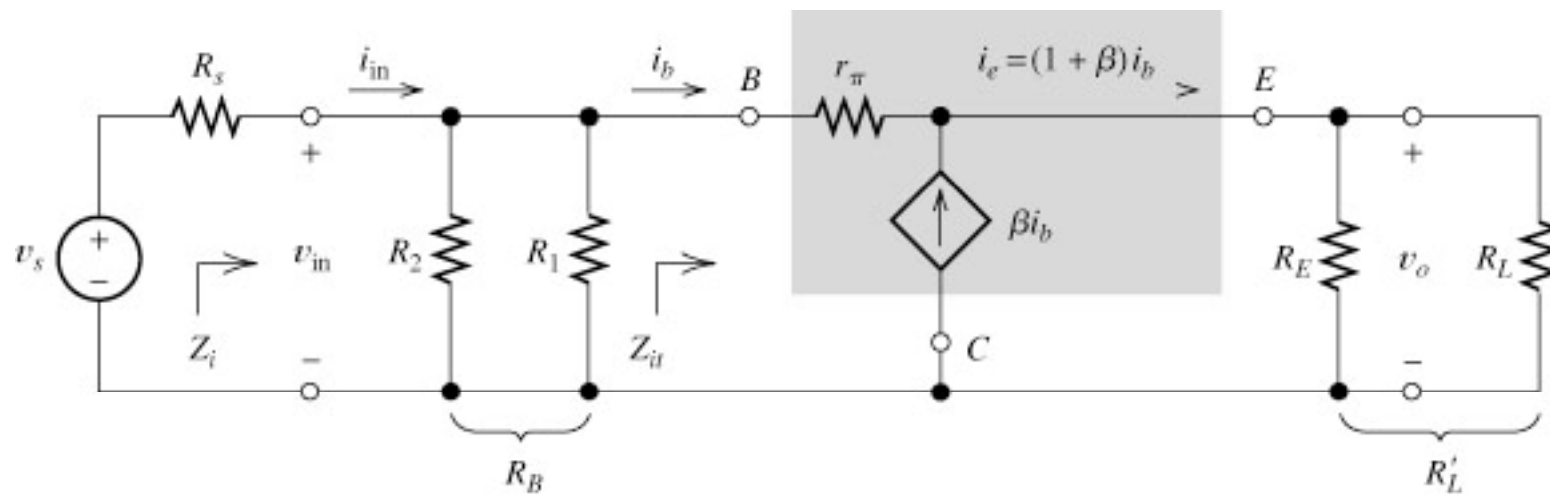

(b) Small-signal midband equivalent circuit

Figure 4.36b Emitter follower.

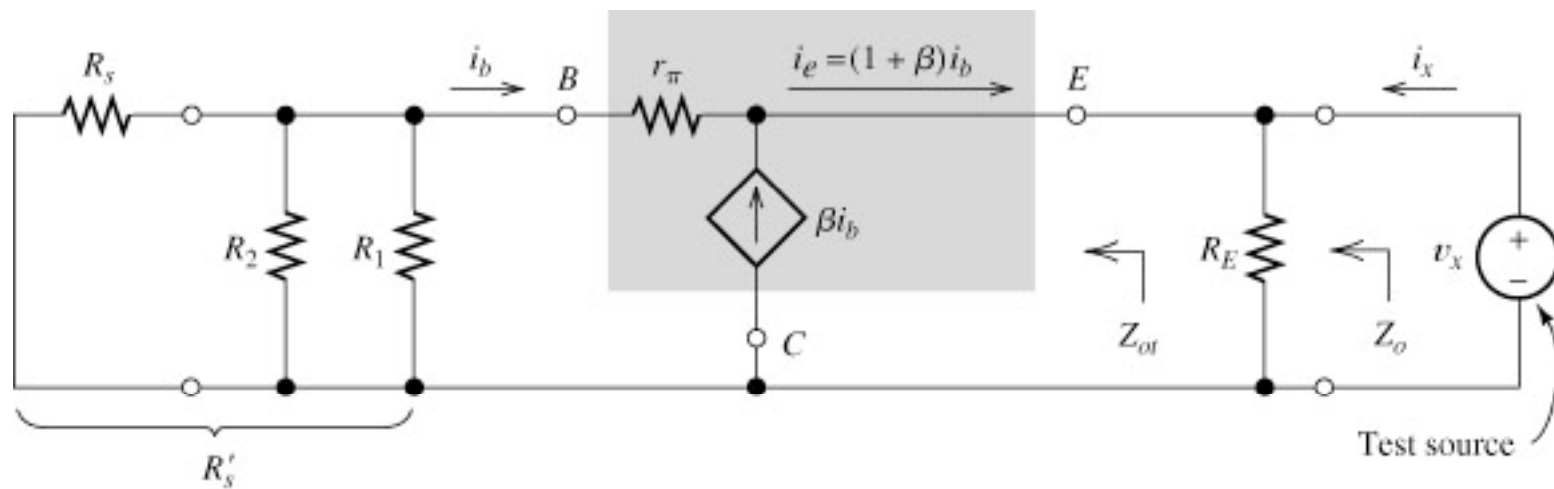

(c) Equivalent circuit used to find output impedance Z_o

Figure 4.36c Emitter follower.

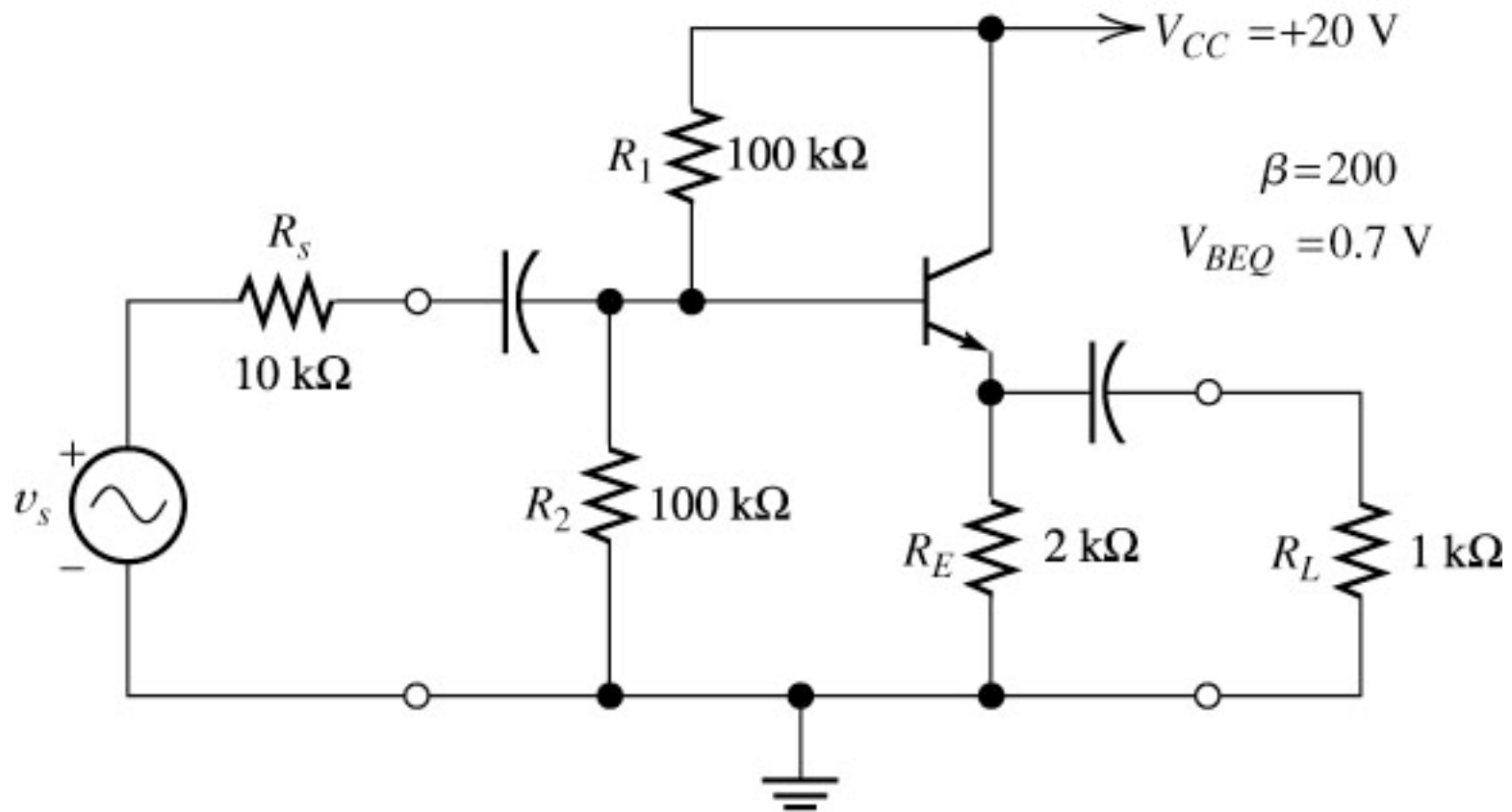

(a) Complete circuit

Figure 4.37a Emitter follower of Example 4.10.

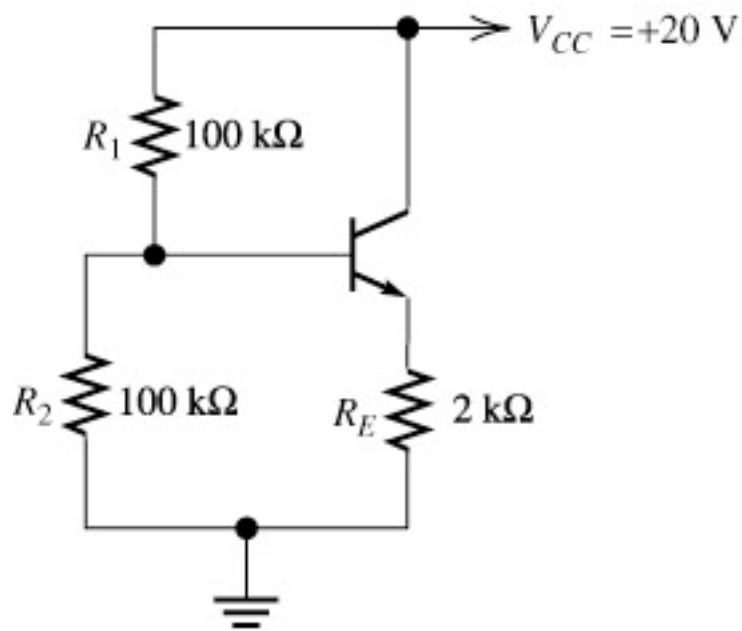

(b) Dc bias circuit

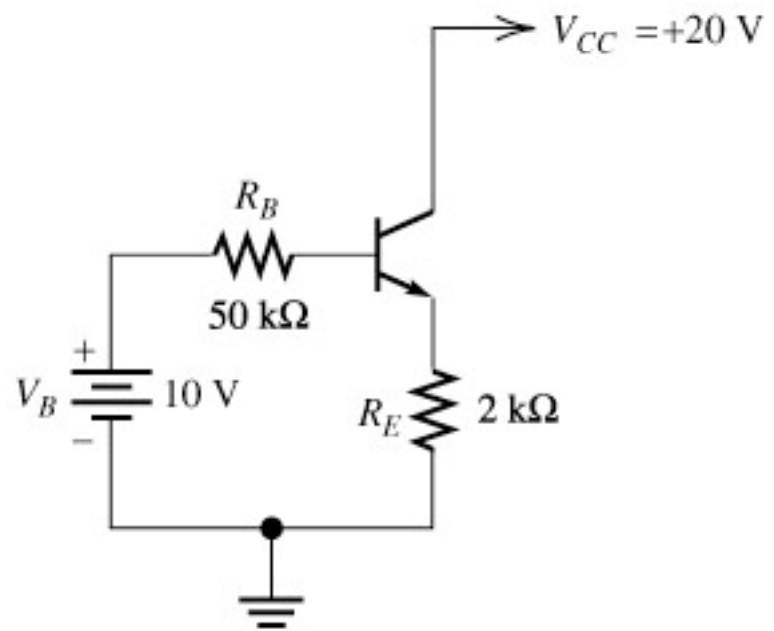

(c) Equivalent bias circuit

Figure 4.37b & c Emitter follower of Example 4.10.

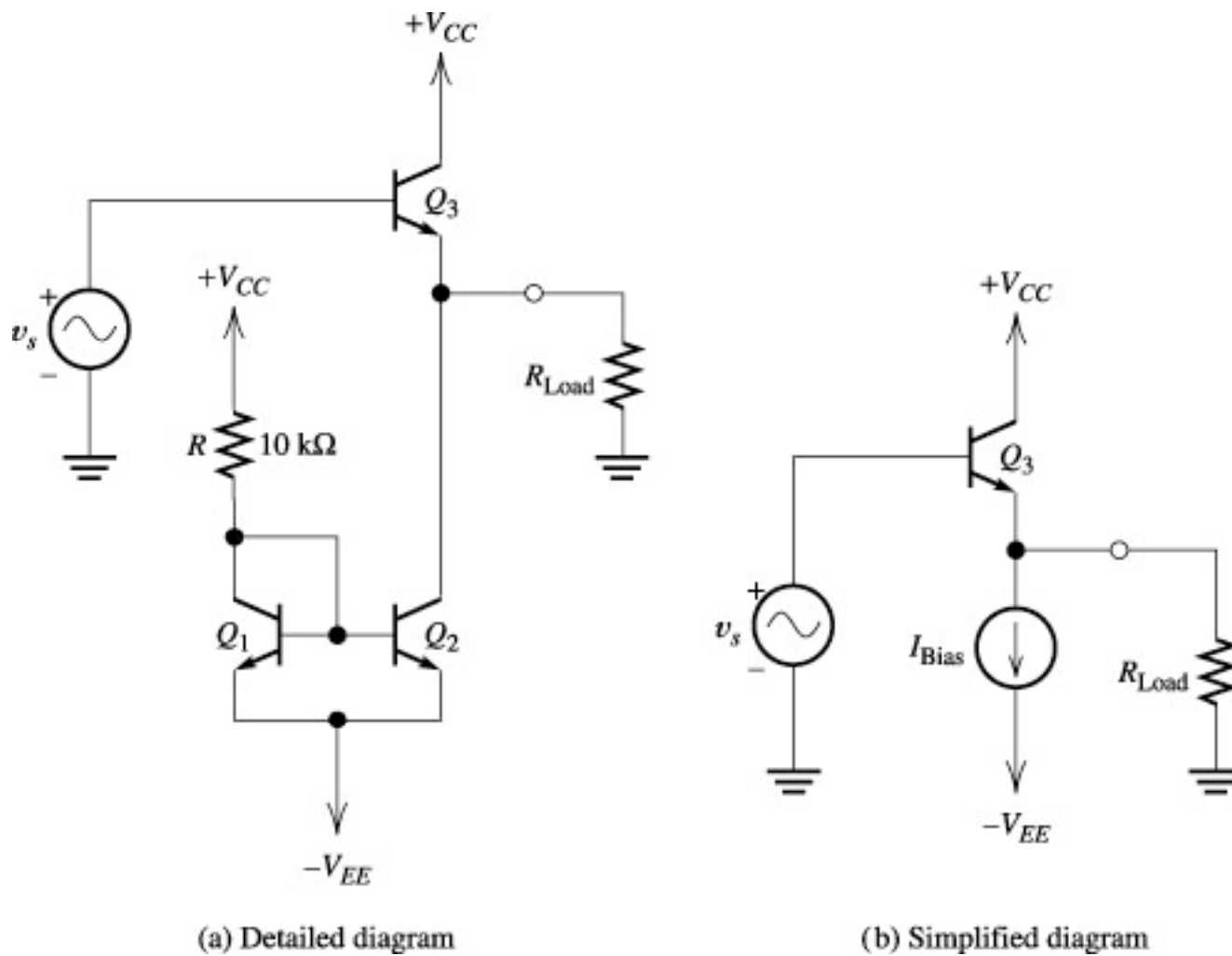

L19 - 01Apr09 **Figure 7.2** Emitter follower with bias current source.

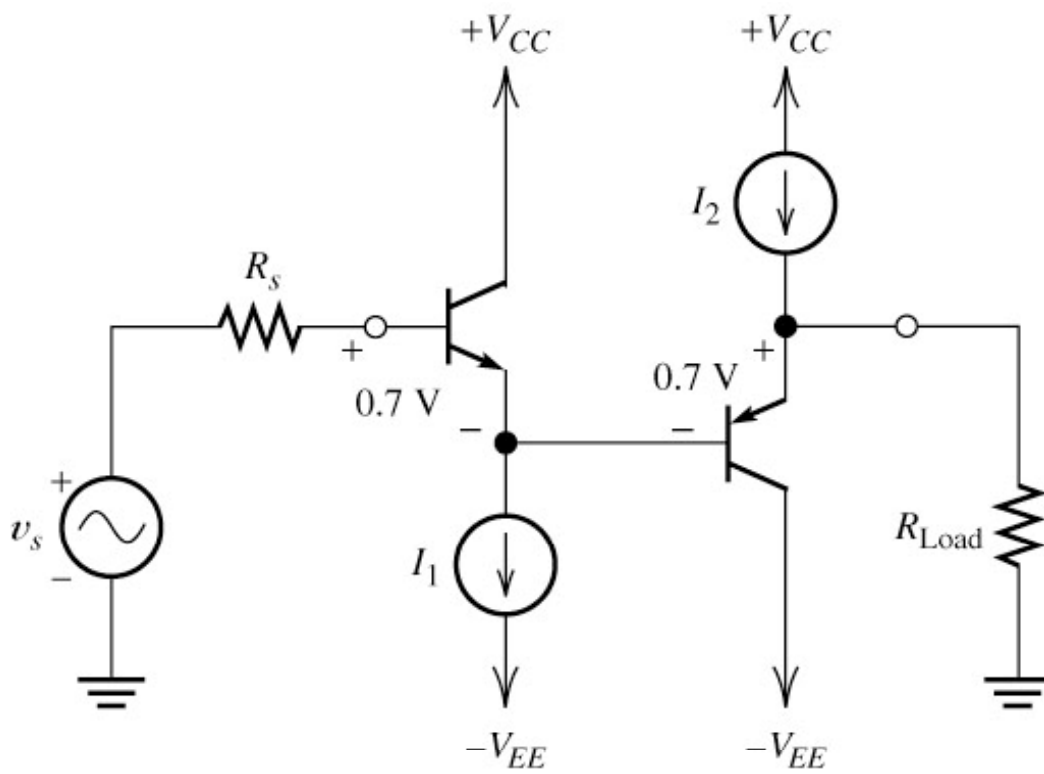

Figure 7.3 The offset voltage can be reduced by cascading a complementary (*pnp*) emitter follower.

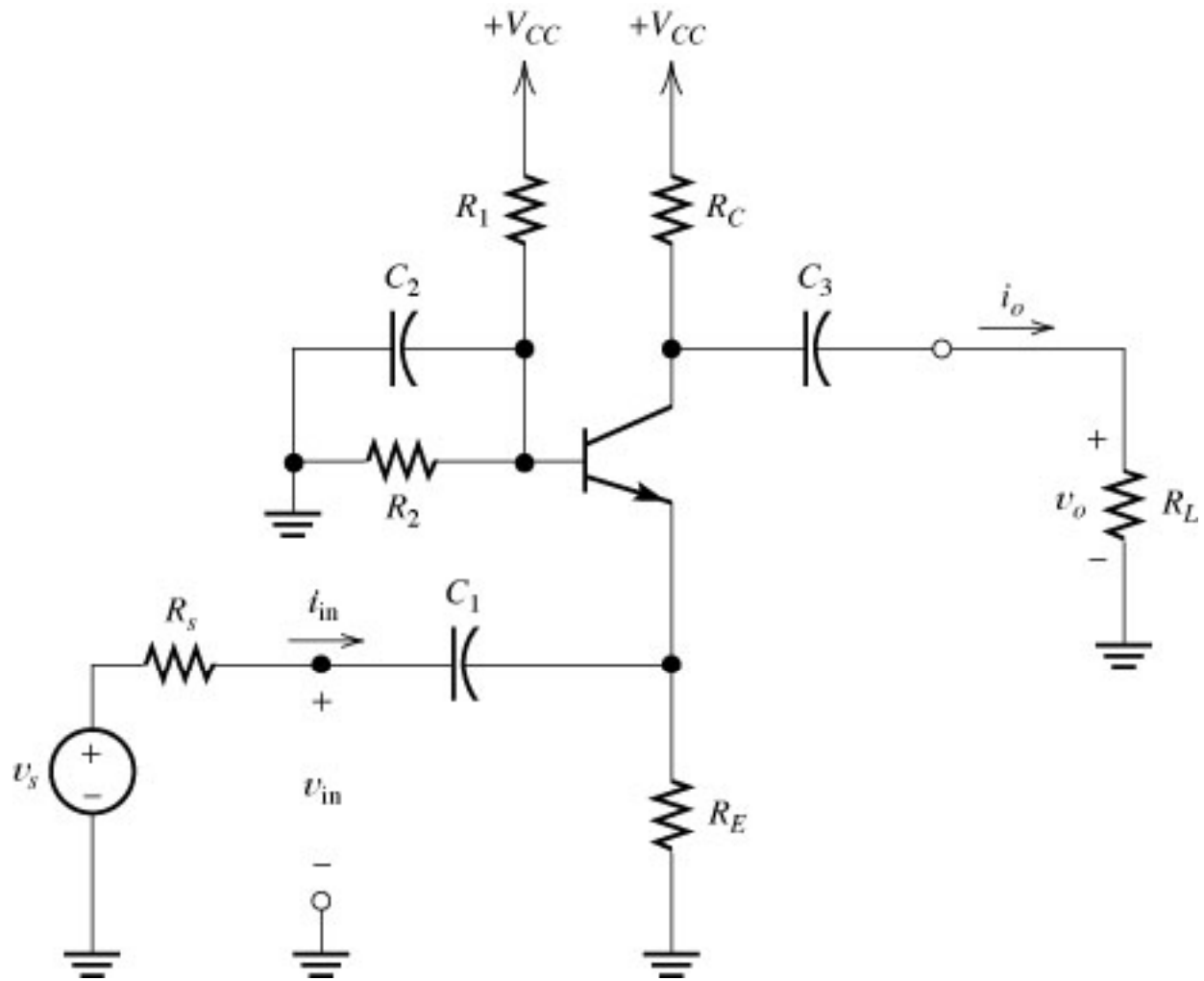

Figure 4.38 Common-base amplifier.

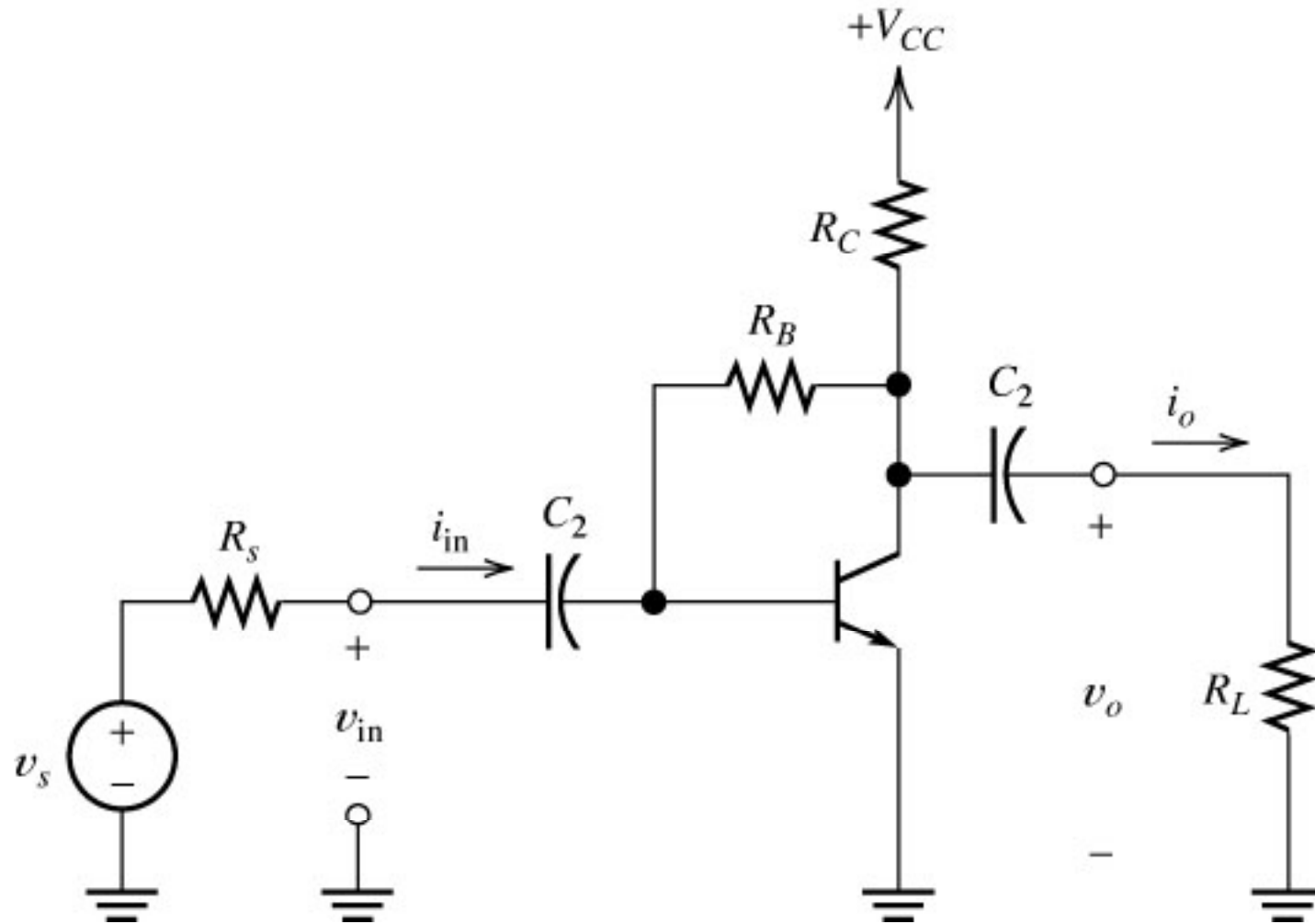

Figure 4.39 Variation of the common-emitter amplifier.

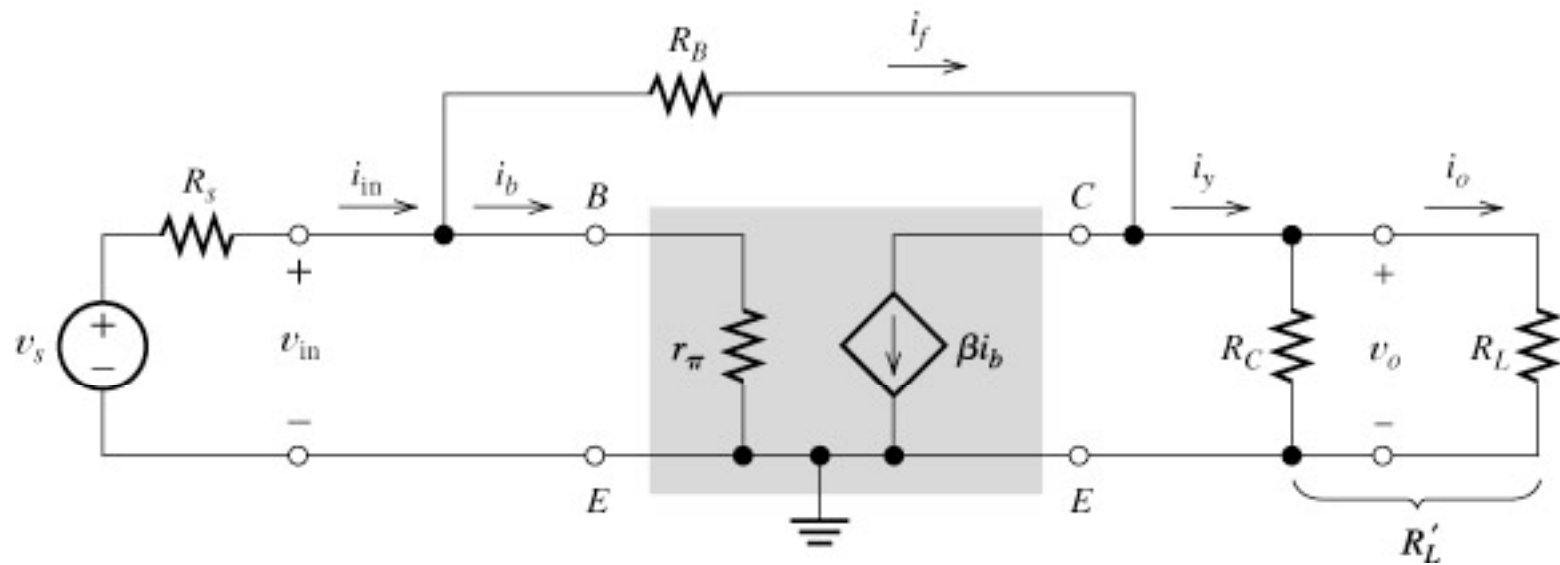
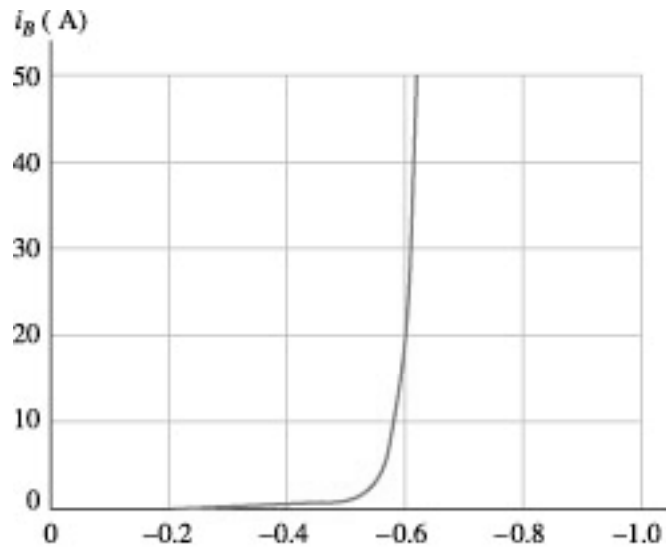
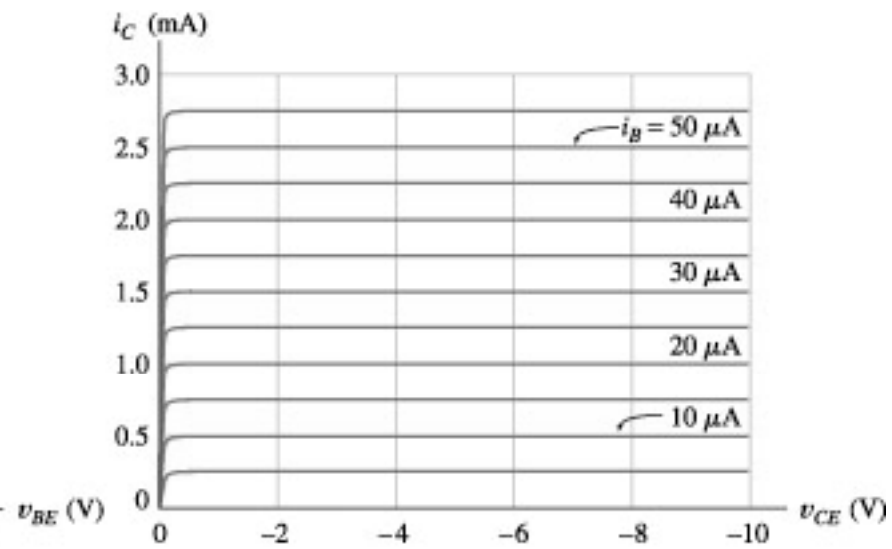

Figure 4.40 Small-signal equivalent circuit for the amplifier of Figure 4.39.



(a) Input



(b) Output

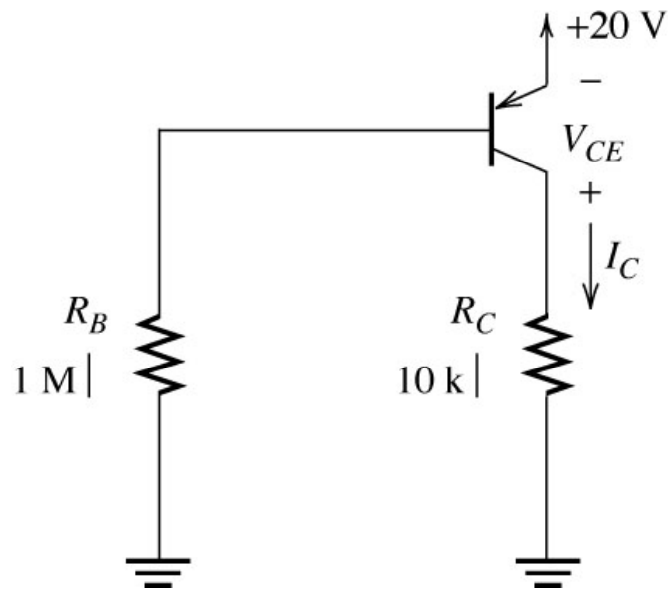

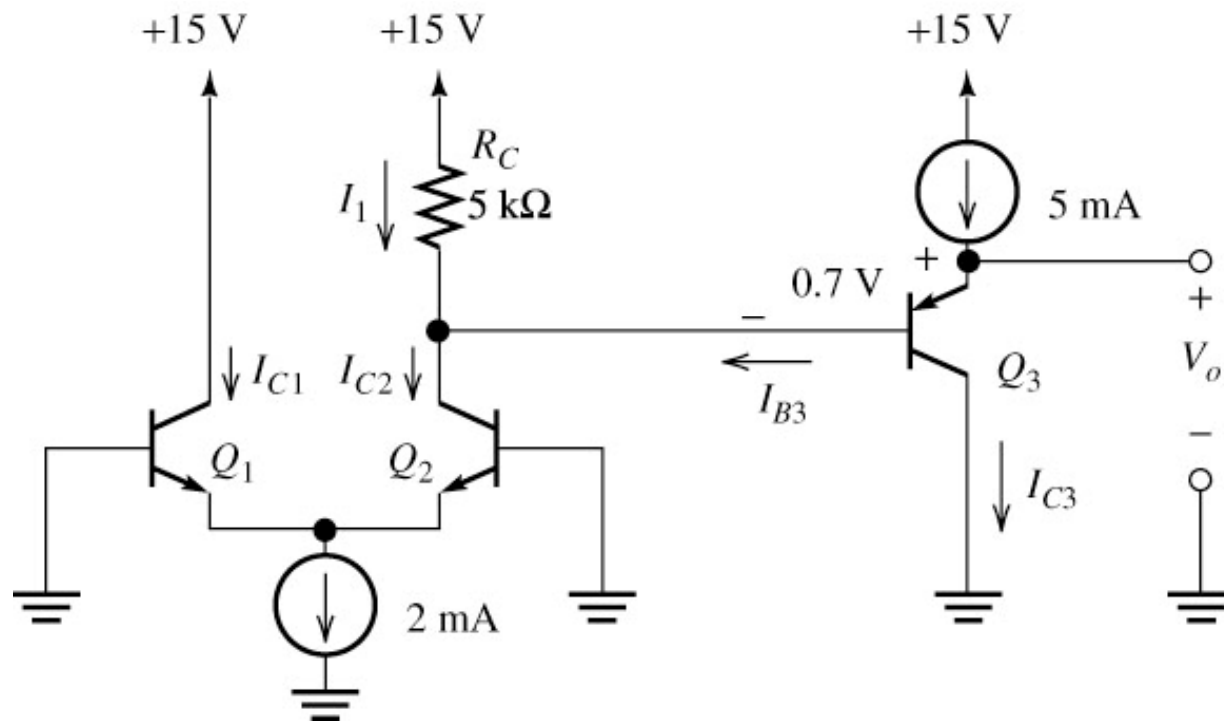

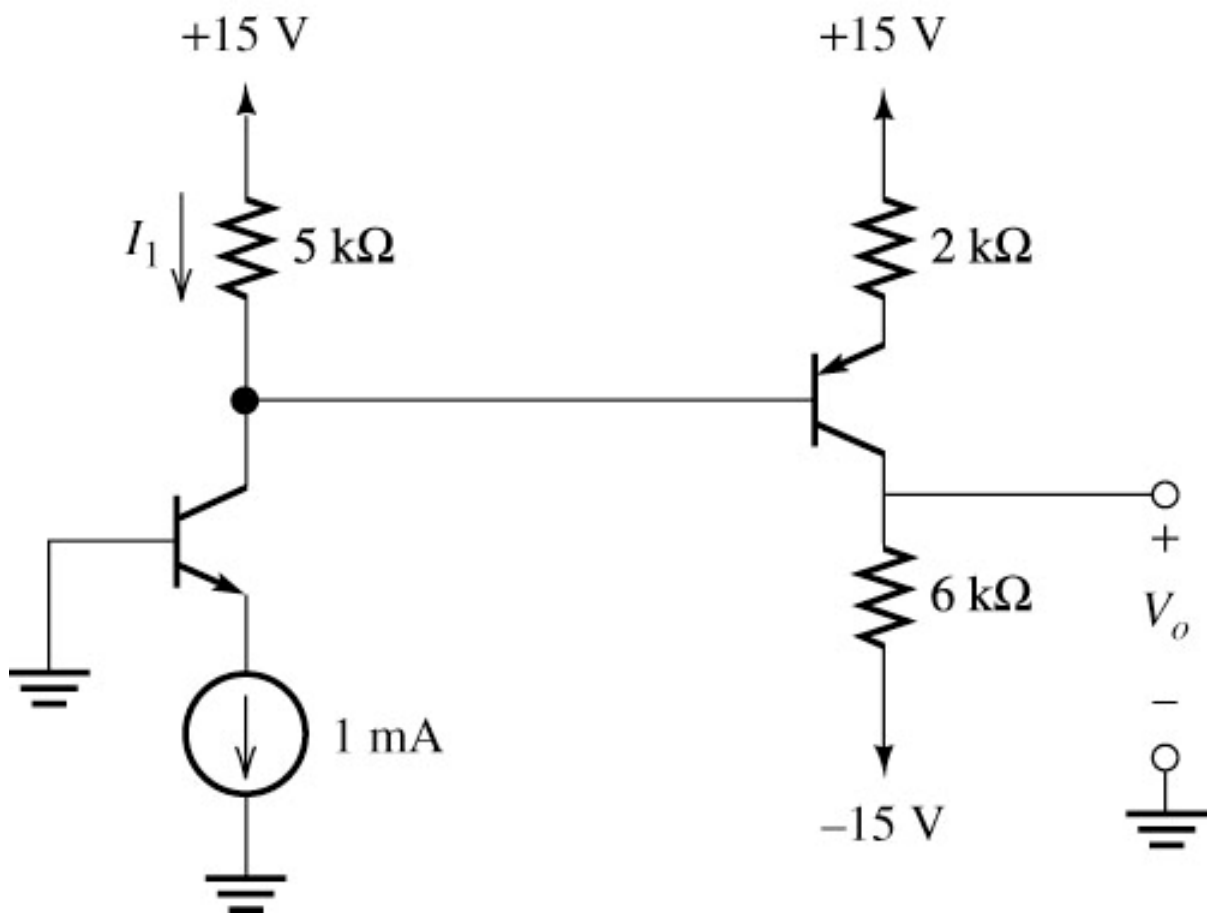

References and Endnotes

- * *Semiconductor Physics & Devices*, by Donald A. Neamen, Irwin, Chicago, 1997.
- Where not otherwise noted, figures with a figure number (e.g., Fig 3.2) are taken from:
 - *Electronics*, 2nd edition, by Allan R. Hambley, Prentice Hall, Upper Saddle River, NJ, © 2000.
- (1) *Microsim PSpice Reference Manual*, Version 8.0, June, 1997. © 1997, MicroSim Corporation. [pspref.pdf]